



BRAKE DISC PAINTED

09.C500.11

The 09.C500.11 painted brake disc is synonymous with reliability

The Brembo brake disc with special UV paint treatment guarantees superior corrosion resistance for the product, thanks to the protective coating on the outer edges and on the disc hub. The UV paint not only gives the disc a clean, shiny appearance but is also beneficial for the environment as the water-based UV paint treatment does not require the use of chemical solvents and is a low energy consumption process.

- ✓ OE-equivalent
- ✓ Brembo quality
- ✓ ECE-R90 certificate
- ✓ Safety
- ✓ Anti-corrosion



Technical specifications



EAN code 8020584226292	Axle Front	Diameter Ø 355 mm
Thickness (TH) 32 mm	Height (A) 83 mm	Number of holes (C) 5
Brake disc type Ventilated	Centering (B) 112 mm	Min. thickness 29 mm

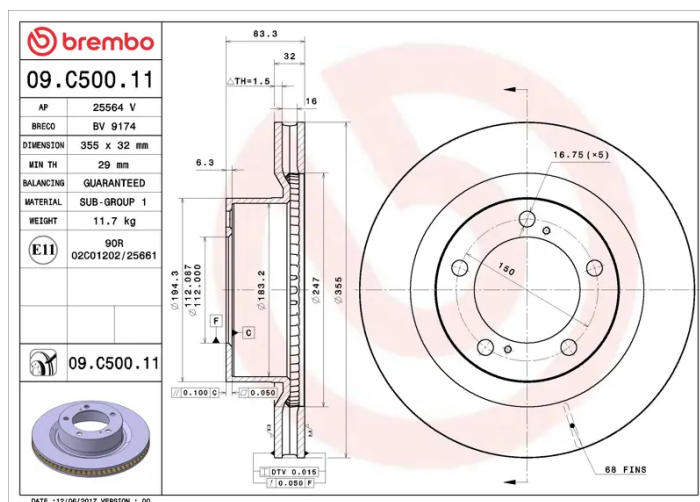

COMPATIBLE VEHICLES

COMPATIBLE OE PART NUMBERS

4351260210	LEXUS
435120C020	TOYOTA
4351260210	TOYOTA
4351260210	TOYOTA (FAW)