



BRAKE DISC PAINTED

09.C545.11

The 09.C545.11 painted brake disc is synonymous with reliability

The Brembo brake disc with special UV paint treatment guarantees superior corrosion resistance for the product, thanks to the protective coating on the outer edges and on the disc hub. The UV paint not only gives the disc a clean, shiny appearance but is also beneficial for the environment as the water-based UV paint treatment does not require the use of chemical solvents and is a low energy consumption process.

- ✓ OE-equivalent
- ✓ Brembo quality
- ✓ ECE-R90 certificate
- ✓ Safety
- ✓ Anti-corrosion
- ✓ Fastening screws



Technical specifications



EAN code
8020584222430

Axle
Front

Diameter \varnothing
296 mm

Thickness (TH)
26 mm

Height (A)
44 mm

Number of holes (C)
5

Brake disc type
Ventilated

Centering (B)
68 mm

Min. thickness
24 mm

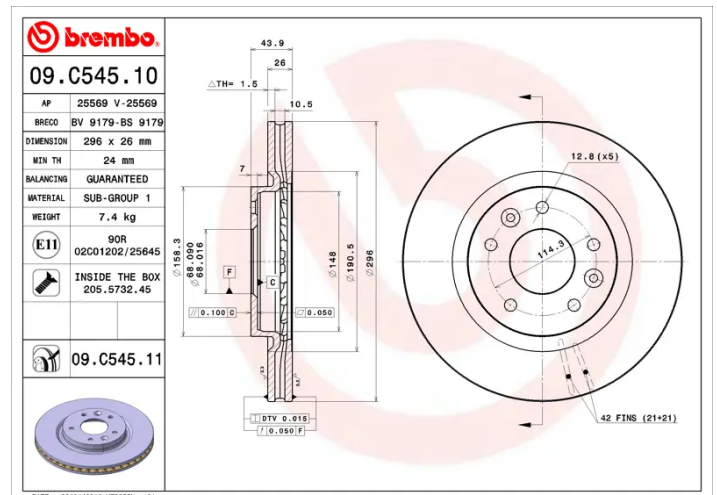

COMPATIBLE VEHICLES

COMPATIBLE OE PART NUMBERS

402064BA0A	NISSAN
------------	--------

402064BTOB	NISSAN
------------	--------

402064EA0A	NISSAN
------------	--------

402064EA0B	NISSAN
------------	--------

D02064BA0ARV	NISSAN
--------------	--------

D02064BA0AVA	NISSAN
--------------	--------

D02064CL0A	NISSAN
------------	--------

402066624R	RENAULT
------------	---------