



THE UNITED KINGDOM VEHICLE APPROVAL AUTHORITY

COMMUNICATION CONCERNING THE APPROVAL GRANTED⁽⁴⁾/-APPROVAL EXTENDED⁽¹⁾/
APPROVAL REFUSED⁽⁴⁾/-APPROVAL WITHDRAWN⁽⁴⁾/-PRODUCTION DEFINITELY
DISCONTINUED⁽⁴⁾ OF A REPLACEMENT BRAKE DISC OR A REPLACEMENT BRAKE DRUM
PURSUANT TO REGULATION NO. 90.02



Approval No: 90R-02C01203/40823

Extension No: 01

Reason for extension:

- 1) Addition of new code: 09.B338.1X
- 2) Removal of Assembly Plant to Argentina
- 3) Update of vehicle list for disc: 09.B338.2X
- 4) Update of supplement level
- 5) Update of geometric specification

1. Applicant's name and address:

BREMBO S.p.A
via Brembo, 25
24035, Curno (BG)
Italy

2. Manufacturer's name and address:

BREMBO S.p.A Divisione Dischi Freno Via G.Maria Scotti, 66 24030 Mapello (BG) Italy	BREMBO POLAND SP. Z O.O. Ul.Rozdzienskiego, 13 Dąbrowa Górnicza, Poland, 41-308
Brembo do Brasil LTDA Av. Fausto Ribeiro Da Silva, 1265 Distrito Industrial De Bandeirinhas 5 32.654-805 Betim-MG Brazil	Brembo North America Inc. 29991 E M60, Homer, MI 49245
Brembo Mexico, SA de CV Platón 100, Parque Industrial Kalos Apodaca, Nuevo León, 66600 Mexico	Brembo (Nanjing) Brake System Co., Ltd.Site 1 No.28 Xijing Road, Jiangning Economic & Technology Zone Nanjing, P.R. China

3. Make and type of brake disc/drum:

Type of disc	Related codes	
BREMBO XTRA	RACING	AP XTRA
09.B338.1X	59.B338.1Z	25315 X
09.B338.2X XU0.01.S3	59.B338.2Z	25316X

Interchangeable Disc Rear (POT TYPE, VENTED, INTERNAL)
GL H 05

4. Vehicles/axles for which the replacement brake disc or a replacement brake drum is approved:
See manufacturer's documentation

5. Submitted for approval on: As before (10 May 2019) and 10 May 2021

6. Technical service responsible for approval tests: VCA Europe S.r.l.

6.1. Date of test report: As before (30 July 2019) and 14 May 2021

6.2. Number of test report: As before (MSU446778) and XSW001292

7. Approval ~~GRANTED/REFUSED/EXTENDED/WITHDRAWN~~⁽¹⁾

8. Place: BRISTOL



9. Date: 16 JUNE 2021

10. Signature:  D LAWLOR
Chief Technical and Statutory Operations Officer

11. Annexed to this communication is a list of documents in the approval file deposited at the administrative services having delivered the approval and which can be obtained upon request.

Any remarks: Approval to Supplement 5

(1) Strike out what does not apply.

	
Application for Approval of a replacement brake Disc According to Reg 90.02 Consolidated to Supplement 5	
Existing approval number (if applicable)	E11 90R-02C01203/40823

VCA Job Number	XSW001292
----------------	-----------

Reasons for extension (if applicable)	1. Addition of new code: 09.B338.1X 2. Removal of Assembly Plant to Argentina 3. Update of vehicle list for disc: 09.B338.2X 4. Update of supplement level 4. Update of geometric specification
---------------------------------------	---

Attachments	Document reference	No of pages
Annex 1	Component Drawings	2
Annex 2	Control plan	30
Annex 3	Production specification	1
Annex 4	List of disc and application	1
Annex 5	Marking specification	2

Notes

Annex 1 Drawings must contain the following:

- Disc/drum diameter, including friction surface diameters (in the case of a disc brake with an integrated parking brake drum, both diameters have to be checked);
- Disc thickness (original dimensions and the minimum permissible wear indication) – mounting face to external friction surface;
- Mounting flange thickness;
- Pitch circle diameter of fixing holes / studs;
- Number of fixing holes / studs;
- Mounting flange diameter;
- Type of centering (e.g. central spigot or mounting bolts /studs);
- In the case of brake discs with integrated parking brake drums the width of the friction surface area and any heat compensation groove(s);
- Additionally, in the case of ventilated brake discs:
 - The type of ventilation (internal/external);
 - The number of ribs and pillars ;
 - The dimensions of the ventilation duct.

Annex 3 production specification must contain:

- Chemical composition and its permitted range, or where appropriate, maximum value, for each element;
- Microstructure as per paragraph 2.2.;
- Mechanical properties as per paragraph 2.3. and their permitted range, or where appropriate, minimum value.

Applicant Name and address	BREMBO S.p.A. Via Brembo, 25 - 24035 Curno (BG) Italy
Manufacturer's name and address	<p>BREMBO S.p.A. Divisione Dischi Freno Via G.Maria Scotti, 66 – 24030 Mapello (BG) – Italy</p> <p>BREMBO POLAND SP. Z O.O. Ul.Rozdzienskiego, 13 DĄBROWA GÓRNICZA, POLAND, 41-308</p> <p>Brembo do Brasil LTDA Av. Fausto Ribeiro Da Silva, 1265 - Distrito Industrial De Bandeirinhas, 5 32.654-805 Betim- MG Brazil</p> <p>Brembo North America Inc. 29991 E M60, Homer, MI 49245</p> <p>Brembo Mexico, SA de CV Platón 100, Parque Industrial Kalos, Apodaca, Nuevo León, 66600, Mexico</p> <p>Brembo (Nanjing) Brake System Co., Ltd. No.28 Xijing Road, Jiangning Economic & Technology Zone, Nanjing, P.R. China</p>

Make of disc/drum	Type of disc/drum	Vehicle application
INTERCHANGEABLE_CAR_128_DIMPLED_Group_01 – Internal Vent Vanes Mat 2 Drum Dimpled		
See Annex 4	See Annex 4	See Annex 4

Geometric Specifications (Attach drawings of all discs/drums as annex 1)

	OE Disc/Drum	Replacement Disc/Drum
Location and dimensions of statutory information <ul style="list-style-type: none"> • The approval number; • Part number • An indication which provides traceability of the production process (e.g. date, batch number, source code); • The minimum thickness of the brake disc or the maximum permissible inside diameter of the brake drum. 	<ul style="list-style-type: none"> • See drawings • See drawings • See annex 5 • See drawings 	<ul style="list-style-type: none"> • See drawings • See drawings • See annex 5 • See drawings
Material	GL H 05 (Sub Group 2)	GL H 05 (Sub Group 2)
Weight in grams	Range from 6400 gr to 6500 gr	Range from 6400 gr to 6500 gr
Disc/Drum Diameter	300 mm	300 mm
Disc Thickness	20 mm	20 mm
Mounting Flange Thickness	See drawings	See drawings
Pitch Circle Diameter of fixing holes/studs	See drawings	See drawings
Number of fixing holes/studs	See drawings	See drawings
Mounting Flange Diameter	See drawings	See drawings
Type of centering (e.g. central spigot or mounting bolts /studs)	See drawings	See drawings
In the case of brake discs with integrated parking brake drums the width of the friction surface area and any heat compensation groove(s)	See drawings	See drawings

<p>In the case of ventilated brake discs:</p> <p>(i) The type of ventilation (internal/external);</p> <p>(ii) The number of ribs and pillars ;</p> <p>(iii) The dimensions of the ventilation duct.</p>	<p>See drawings</p>	<p>See drawings</p>
---	---------------------	---------------------

Component Description

<p>Manufacturer of the un-machined part</p>	<p>BREMBO S.p.A. Divisione Dischi Freno Via G.Maria Scotti, 66 – 24030 Mapello (BG) – Italy</p> <p>BREMBO POLAND SP. Z O.O. Ul.Rozdzienskiego, 13 DĄBROWA GÓRNICZA, POLAND, 41-308</p> <p>Brembo North America Inc. 29991 E M60, Homer, MI 49245</p> <p>Brembo Mexico, SA de CV Platón 100, Parque Industrial Kalos, Apodaca, Nuevo León, 66600, Mexico</p> <p>Brembo (Nanjing) Brake System Co., Ltd. No.28 Xijing Road, Jiangning Economic & Technology Zone, Nanjing, P.R. China</p>
<p>A description of the process of manufacture of the un-machined part;</p>	<p>Casting Production</p>
<p>Proof of the reliability of the process (e.g. freedom from cracks and cavities, dimensions) attach as annex 2</p>	<p>COP VCA Control Plan</p>

Material Composition	Chemical composition	See Annex 3
	Microstructure	See Annex 3
	Mechanical properties (brinell Hardness to ISO 6506-1:2005)	See Annex 3
	Tensile strength to ISO 6892:1998	See Annex 3
Corrosion or surface protection	Oil or Painting	
Description of balancing methods (including maximum error)	See Drawings; The balance value is 20 Nmm and Brembo check disks with a machine and if the value is bigger to 20 the machine works discs	
Amount of wear allowed (minimum thickness in the case of brake discs or the maximum internal diameter in the case of brake drums).	See drawings	

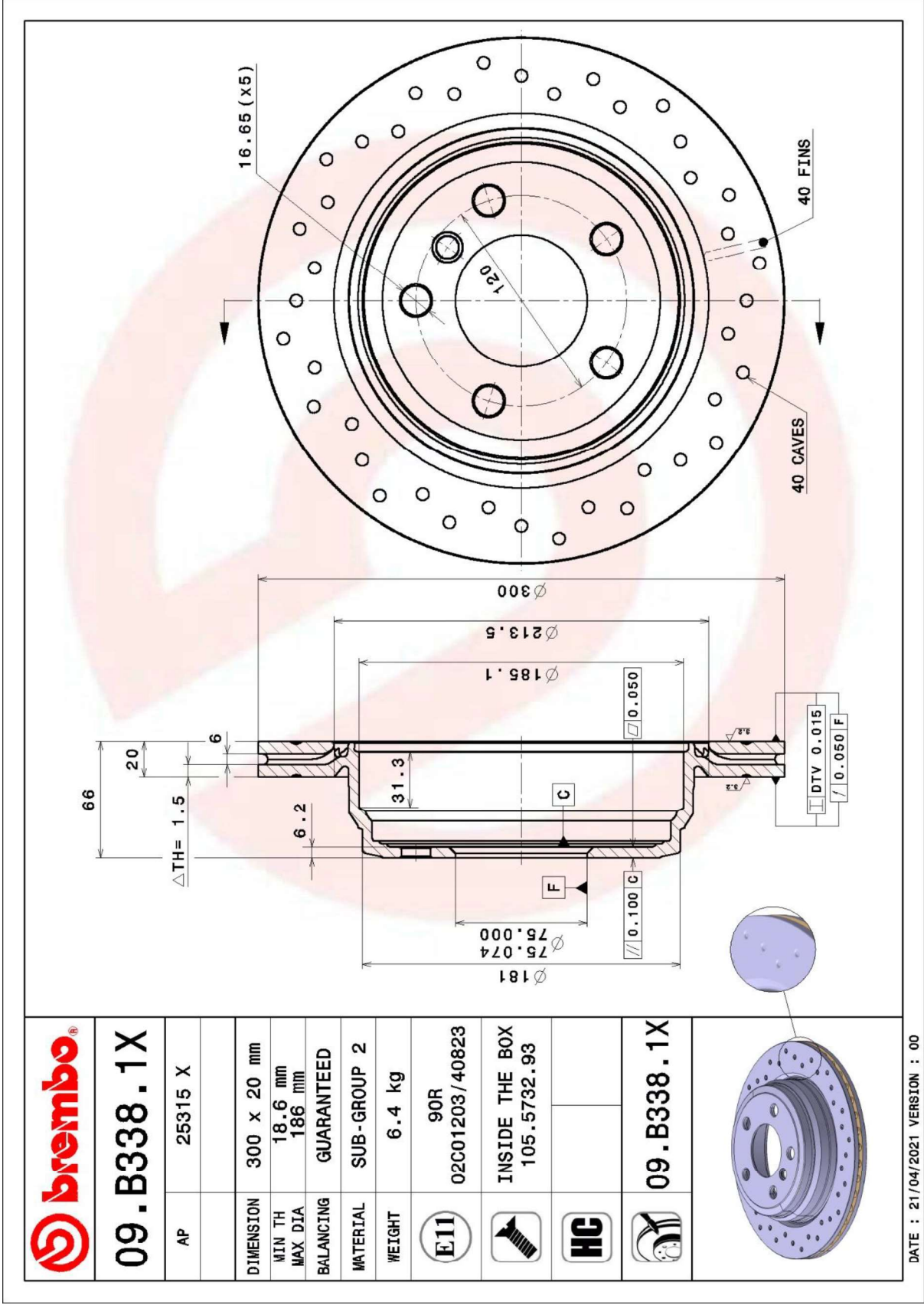

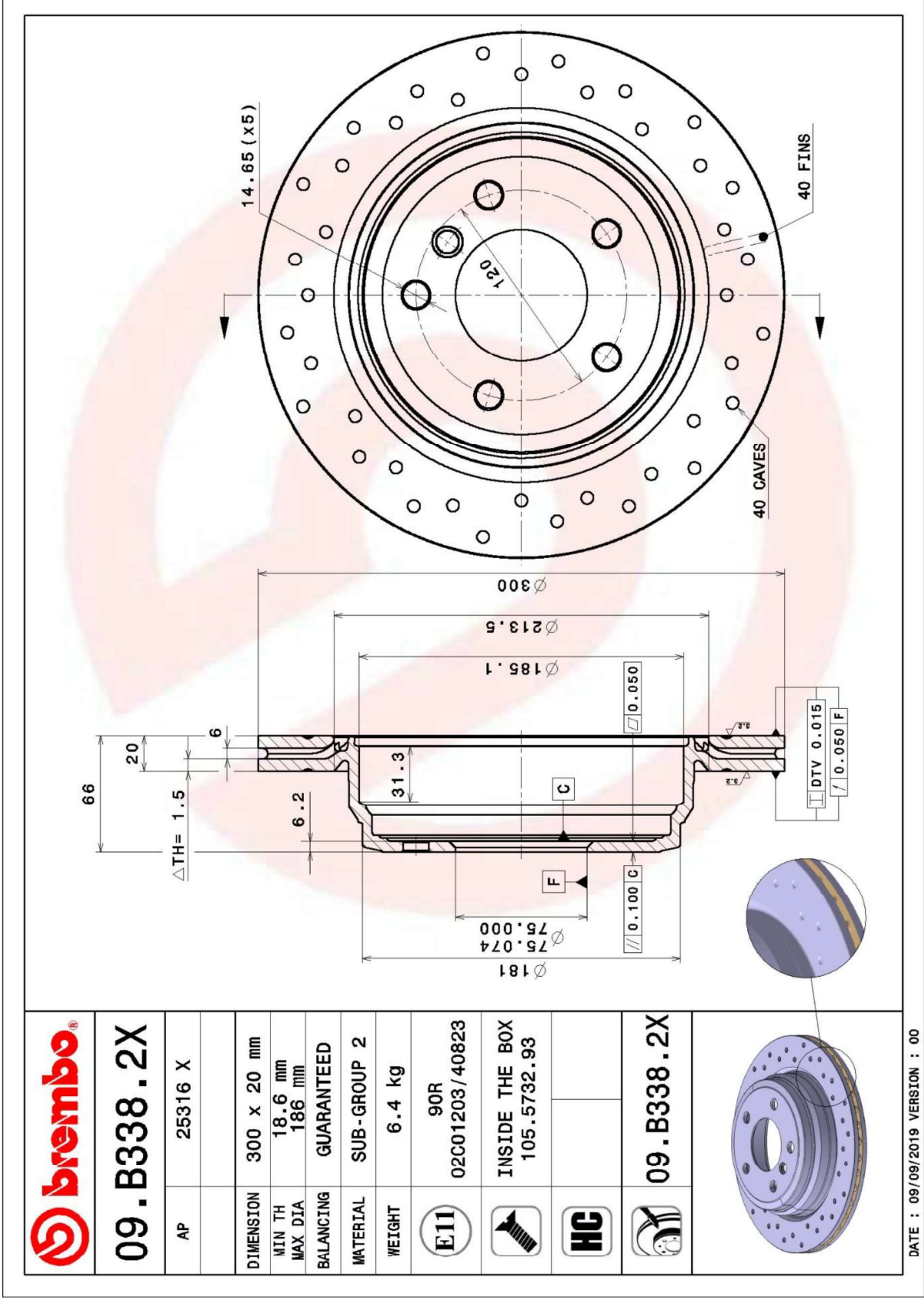

09.B338.2X	
AP	25316 X
DIMENSION	300 x 20 mm
MIN TH	18.6 mm
MAX DIA	186 mm
BALANCING	GUARANTEED
MATERIAL	SUB-GROUP 2
WEIGHT	6.4 kg
	90R
	02C01203/40823
	INSIDE THE BOX
	105.5732.93
	09.B338.2X

DATE : 09/09/2019 VERSION : 00



GL H 05 (Sub Group 2)		
Chemical composition	% Carbon content	3.60 ÷ 3.90
	% Silicon content	1.60 ÷ 2.20
	% Manganese content	0.40 MIN
	% Chromium content	0.35 MAX
	% Copper content	0.30 ÷ 0.70
Microstructure	Matrix	Pearlitic; fine lamellar
Mechanical properties	Hardness ISO 6506-1:2005 HBW	160 – 210
	Tensile strength to ISO 6892:1998 N/mm ²	160 MIN

BREMBO XTRA	RACING	AP XTRA	OE REFERENCE	WEIGHT DISC [kg]	APPLICATION	MODEL	YEAR FROM	YEAR TO	FRONT - REAR	VEHICLE MAX SPEED [km/h]	PAY LOAD [kg]
09.B338.1X	59.B338.1Z	25315 X	34216 792 229 34216 797 344	6,5	BMW	3 (F30, F35, F80)	10/11	-	REAR	250	2.080
09.B338.1X	59.B338.1Z	25315 X	34216 792 229 34216 797 344	6,5	BMW	3 Gran Turismo (F34)	03/13	-	REAR	230	2.270
09.B338.1X	59.B338.1Z	25315 X	34216 792 229 34216 797 344	6,5	BMW	3 Touring (F31)	10/11	-	REAR	233	2.205
09.B338.1X	59.B338.1Z	25315 X	34216 792 229 34216 797 344	6,5	BMW	4 Convertible (F33, F83)	10/13	-	REAR	250	2.200
09.B338.1X	59.B338.1Z	25315 X	34216 792 229 34216 797 344	6,5	BMW	4 Coupe (F32, F82)	07/13	-	REAR	250	2.150
09.B338.1X	59.B338.1Z	25315 X	34216 792 229 34216 797 344	6,5	BMW	4 Gran Coupe (F36)	03/14	-	REAR	250	2.200
09.B338.1X	59.B338.1Z	25315 X	34216 792 229 34216 797 344	6,5	BMW (BRILLIANCE)	3 SERIES (F30, F35)	07/12	-	Rear	250	2.135
09.B338.2X XU0.01.S3	59.B338.2Z	25316X	34216 855 657 34216 855 008	6,4	BMW	1 (E81)	09/06	09/12	REAR	250	1910
09.B338.2X XU0.01.S3	59.B338.2Z	25316X	34216 855 657 34216 855 008	6,4	BMW	1 (E87)	11/03	01/13	REAR	250	1920
09.B338.2X XU0.01.S3	59.B338.2Z	25316X	34216 855 657 34216 855 008	6,4	BMW	3 (E90)	01/05	12/11	REAR	250	2080
09.B338.2X XU0.01.S3	59.B338.2Z	25316X	34216 855 657 34216 855 008	6,4	BMW	3 Convertible (E93)	08/06	12/13	REAR	245	2115
09.B338.2X XU0.01.S3	59.B338.2Z	25316X	34216 855 657 34216 855 008	6,4	BMW	3 Coupe (E92)	06/06	12/13	REAR	250	2030
09.B338.2X XU0.01.S3	59.B338.2Z	25316X	34216 855 657 34216 855 008	6,4	BMW	3 Touring (E91)	09/05	06/12	REAR	248	2225
09.B338.2X XU0.01.S3	59.B338.2Z	25316X	34216 855 657 34216 855 008	6,4	BMW	X1 (E84)	03/09	06/15	REAR	230	2215
09.B338.2X XU0.01.S3	59.B338.2Z	25316X	34216 855 657 34216 855 008	6,4	BMW (BRILLIANCE)	X1 (E84)	03/12	-	Rear	223	2.215

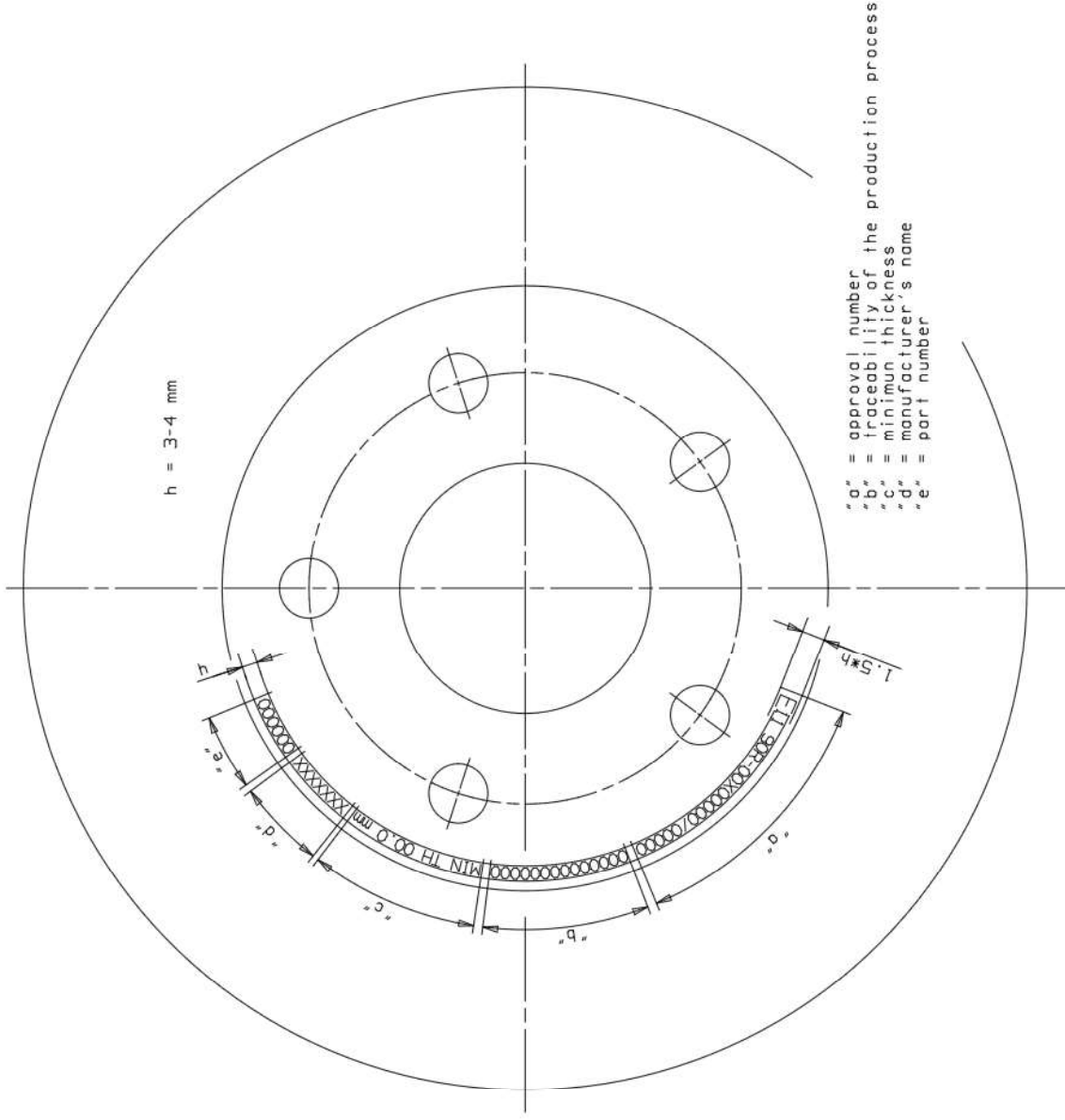

- "a" = approval number
- "b" = traceability of the production process
- "c" = minimum thickness
- "d" = manufacturer's name
- "e" = part number



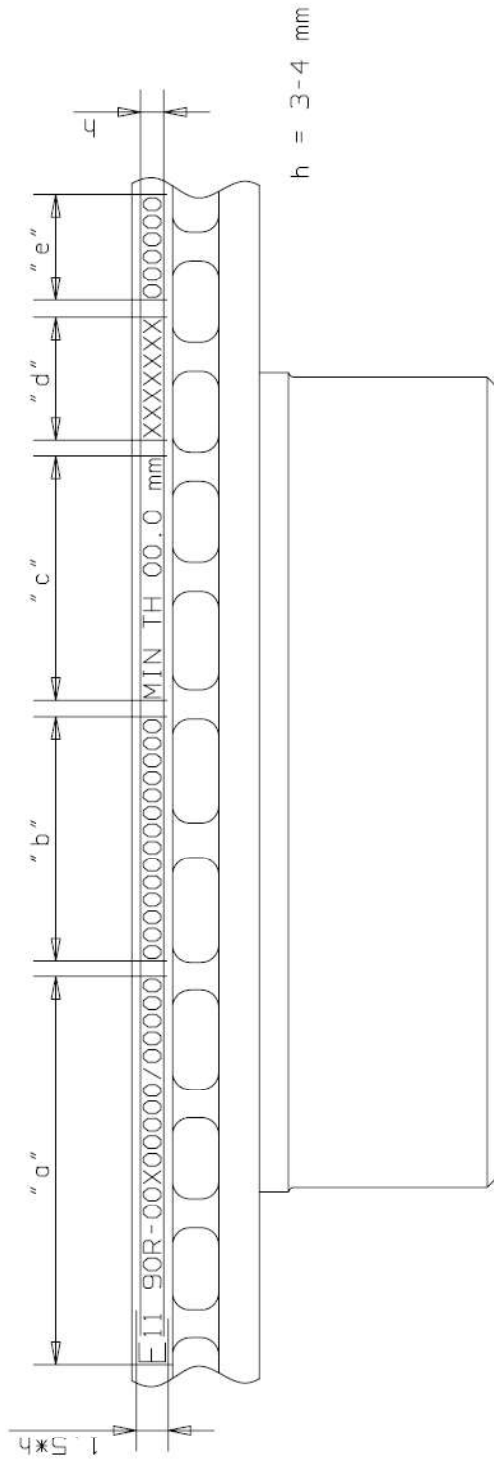

- "a" = approval number
- "b" = traceability of the production process
- "c" = minimum thickness
- "d" = manufacturer's name
- "e" = part number