



BRAKE DISC PAINTED

08.D225.11

The 08.D225.11 painted brake disc is synonymous with reliability

The Brembo brake disc with special UV paint treatment guarantees superior corrosion resistance for the product, thanks to the protective coating on the outer edges and on the disc hub. The UV paint not only gives the disc a clean, shiny appearance but is also beneficial for the environment as the water-based UV paint treatment does not require the use of chemical solvents and is a low energy consumption process.

- ✓ OE-equivalent
- ✓ Brembo quality
- ✓ ECE-R90 certificate
- ✓ Safety
- ✓ Anti-corrosion



Technical specifications



EAN code	Axle	Diameter Ø
8020584234518	Rear	264 mm
Thickness (TH)	Height (A)	Number of holes (C)
10 mm	44 mm	5
Brake disc type	Centering (B)	Min. thickness
Solid	60 mm	8 mm

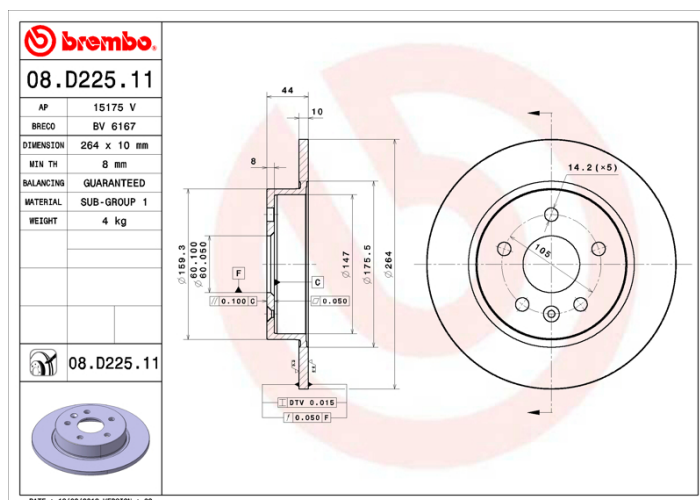

COMPATIBLE VEHICLES

COMPATIBLE OE PART NUMBERS

13514610	BUICK (SGM)
----------	-------------

13514611	BUICK (SGM)
----------	-------------

13514610	CHEVROLET (SGM)
----------	-----------------

13509119	OPEL
----------	------

13514611	OPEL
----------	------

13514612	OPEL
----------	------

13597355	OPEL
----------	------

13509119	VAUXHALL
----------	----------

13514612	VAUXHALL
----------	----------