



BRAKE PAD

P 50 161

The P 50 161 brake pad is synonymous with reliability

The Brembo brake pad guarantees ultimate safety when braking thanks to the use of more than 100 different compounds, designed according to the type of vehicle and use. Stopping distances reduced to a minimum, maximum driving comfort and silent operation are the most important features of Brembo materials. Brembo brake pads are supplied together with an extensive range of accessories and assembly kits for professional-standard installation.



- ✓ OE-equivalent
- ✓ Brembo quality
- ✓ ECE-R90 certificate
- ✓ Safety
- ✓ Performance
- ✓ Comfort
- ✓ With accessories

Technical specifications

EAN code 8020584117996	Axle Rear	Thickness 19 mm
Width 132 mm	Height 70 mm	Braking system TRW
Wear indicator Prepared for wear indicator	WVA number 22723,22724	Accessories With accessories With anti-squeal shim With brake caliper bolts

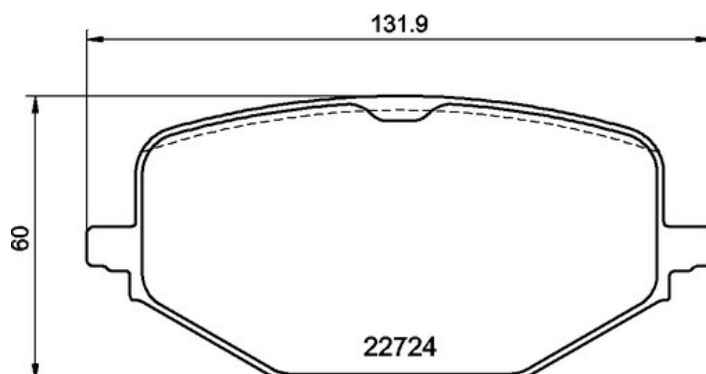
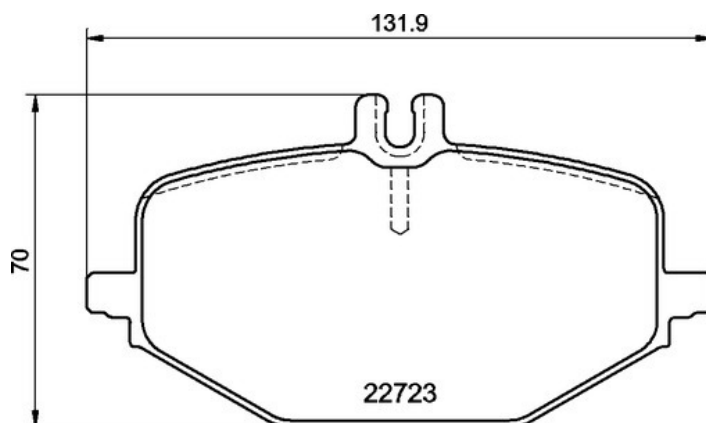

COMPATIBLE VEHICLES

COMPATIBLE OE PART NUMBERS

0004203805	MERCEDES-BENZ
0004205102	MERCEDES-BENZ
0004207303	MERCEDES-BENZ
A0004205102	MERCEDES-BENZ
A0004207303	MERCEDES-BENZ