



# BRAKE DISC PAINTED

## 09.C896.11

The 09.C896.11 painted brake disc is synonymous with reliability

The Brembo brake disc with special UV paint treatment guarantees superior corrosion resistance for the product, thanks to the protective coating on the outer edges and on the disc hub. The UV paint not only gives the disc a clean, shiny appearance but is also beneficial for the environment as the water-based UV paint treatment does not require the use of chemical solvents and is a low energy consumption process.

- ✓ OE-equivalent
- ✓ Brembo quality
- ✓ ECE-R90 certificate
- ✓ Safety
- ✓ High carbon
- ✓ Anti-corrosion
- ✓ PVT ventilation
- ✓ Fastening screws



### Technical specifications

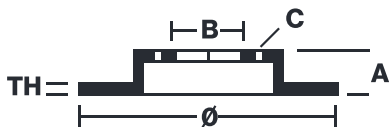

EAN code  
8020584232293

Axle  
Front

Diameter Ø  
332 mm

Thickness (TH)  
30 mm

Height (A)  
62 mm

Number of holes (C)  
5

Brake disc type  
Ventilated

Centering (B)  
75 mm

Min. thickness  
28,4 mm

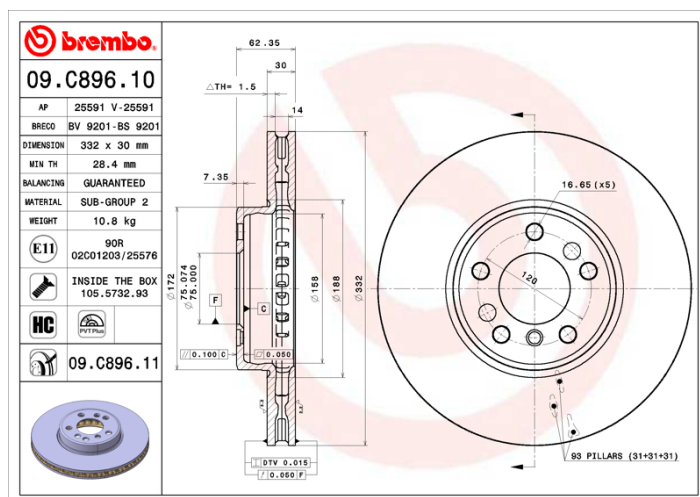

## COMPATIBLE OE PART NUMBERS

34116750713 BMW

---

34116756045 BMW

---

34116765457 BMW

---

34116766036 BMW

---

34116794300 BMW

---

34116794304 BMW

---

34116859679 BMW

---