



# BRAKE PAD

## P 50 163

The P 50 163 brake pad is synonymous with reliability

The Brembo brake pad guarantees ultimate safety when braking thanks to the use of more than 100 different compounds, designed according to the type of vehicle and use. Stopping distances reduced to a minimum, maximum driving comfort and silent operation are the most important features of Brembo materials. Brembo brake pads are supplied together with an extensive range of accessories and assembly kits for professional-standard installation.

- ✓ OE-equivalent
- ✓ Brembo quality
- ✓ ECE-R90 certificate
- ✓ Safety
- ✓ Performance
- ✓ Comfort



### Technical specifications

EAN code                      Thickness  
**8020584118221**            **16 mm**

Width                              Height  
**178 mm**                      **91 mm**

Wear indicator                WVA number  
**Prepared for wear indicator**    **26128**

Braking system  
**Brembo**

Accessories  
**With anti-squeal shim**  
**With counterweights**

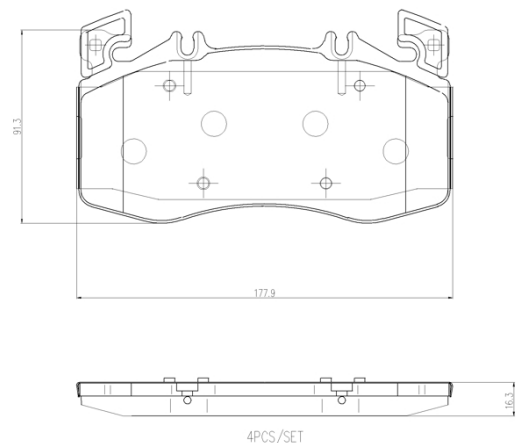

## COMPATIBLE OE PART NUMBERS

|            |               |
|------------|---------------|
| 0004202203 | MERCEDES-BENZ |
|------------|---------------|

|            |               |
|------------|---------------|
| 0004202306 | MERCEDES-BENZ |
|------------|---------------|

|            |               |
|------------|---------------|
| 0004203604 | MERCEDES-BENZ |
|------------|---------------|

|            |               |
|------------|---------------|
| 0004209802 | MERCEDES-BENZ |
|------------|---------------|

|             |               |
|-------------|---------------|
| A0004202203 | MERCEDES-BENZ |
|-------------|---------------|

|             |               |
|-------------|---------------|
| A0004202306 | MERCEDES-BENZ |
|-------------|---------------|

|             |               |
|-------------|---------------|
| A0004202706 | MERCEDES-BENZ |
|-------------|---------------|

|             |               |
|-------------|---------------|
| A0004203604 | MERCEDES-BENZ |
|-------------|---------------|

|             |               |
|-------------|---------------|
| A0004209802 | MERCEDES-BENZ |
|-------------|---------------|