



BRAKE DISC PAINTED

09.B504.11

The 09.B504.11 painted brake disc is synonymous with reliability

The Brembo brake disc with special UV paint treatment guarantees superior corrosion resistance for the product, thanks to the protective coating on the outer edges and on the disc hub. The UV paint not only gives the disc a clean, shiny appearance but is also beneficial for the environment as the water-based UV paint treatment does not require the use of chemical solvents and is a low energy consumption process.

- ✓ OE-equivalent
- ✓ Brembo quality
- ✓ ECE-R90 certificate
- ✓ Safety
- ✓ High carbon
- ✓ Anti-corrosion
- ✓ PVT ventilation



Technical specifications

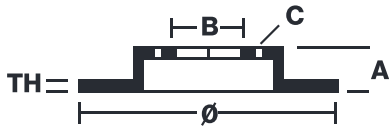

EAN code 8020584221914	Axle Rear	Diameter Ø 365 mm
Thickness (TH) 25 mm	Height (A) 49 mm	Number of holes (C) 5
Brake disc type Ventilated	Centering (B) 79 mm	Min. thickness 22 mm

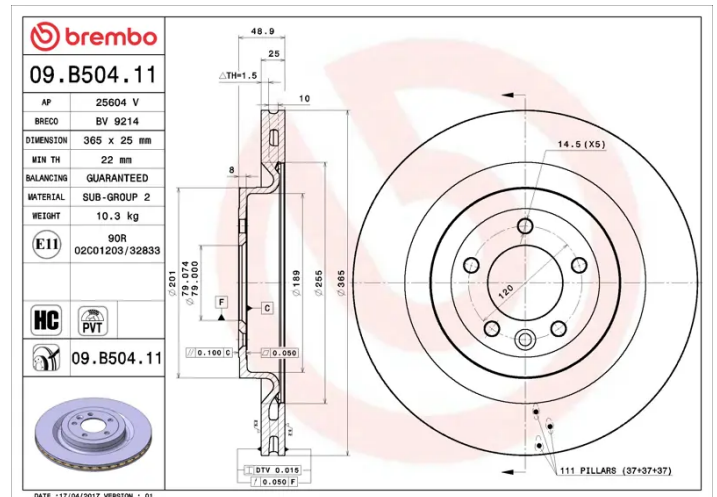

COMPATIBLE VEHICLES

COMPATIBLE OE PART NUMBERS

LR033303 LAND ROVER

LR099038 LAND ROVER

LR161899 LAND ROVER

LR189047 LAND ROVER
