



BRAKE PAD

P 50 011

The P 50 011 brake pad is synonymous with reliability





The Brembo brake pad guarantees ultimate safety when braking thanks to the use of more than 100 different compounds, designed according to the type of vehicle and use. Stopping distances reduced to a minimum, maximum driving comfort and silent operation are the most important features of Brembo materials. Brembo brake pads are supplied together with an extensive range of accessories and assembly kits for professional-standard installation.

- ✓ OE-equivalent
- ✓ Brembo quality
- ✓ ECE-R90 certificate
- ✓ Safety
- ✓ Performance
- ✓ Comfort

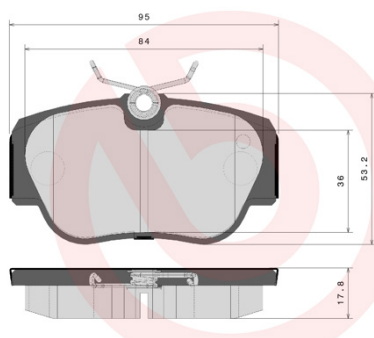

Technical specifications

EAN code 8020584053836	Axle Front	Thickness 18 mm
Width 95 mm	Height 53 mm	Braking system Lucas
Wear indicator Prepared for wear indicator	WVA number 21055	Accessories With brake caliper bolts

	P 50 011		407.E672.114
			BOLT M8x1,25x21 05.E659.000 - x2 
WVA: 21055 QTY: x4			
<small>DATE : 22/11/2023 VERSION : 00</small>			

COMPATIBLE VEHICLES

COMPATIBLE OE PART NUMBERS

0004208920	MERCEDES-BENZ
------------	---------------

0004209120	MERCEDES-BENZ
------------	---------------

0014201020	MERCEDES-BENZ
------------	---------------

0014208120	MERCEDES-BENZ
------------	---------------

0014209620	MERCEDES-BENZ
------------	---------------

0024200220	MERCEDES-BENZ
------------	---------------

A0004208920	MERCEDES-BENZ
-------------	---------------

A0004209120	MERCEDES-BENZ
-------------	---------------

A0014201020	MERCEDES-BENZ
-------------	---------------

A0014208120	MERCEDES-BENZ
-------------	---------------

A0014209620	MERCEDES-BENZ
-------------	---------------

A0024200220	MERCEDES-BENZ
-------------	---------------