



BRAKE PAD

P 50 094

The P 50 094 brake pad is synonymous with reliability

The Brembo brake pad guarantees ultimate safety when braking thanks to the use of more than 100 different compounds, designed according to the type of vehicle and use. Stopping distances reduced to a minimum, maximum driving comfort and silent operation are the most important features of Brembo materials. Brembo brake pads are supplied together with an extensive range of accessories and assembly kits for professional-standard installation.

- ✓ OE-equivalent
- ✓ Brembo quality
- ✓ ECE-R90 certificate
- ✓ Safety
- ✓ Performance
- ✓ Comfort



Technical specifications

EAN code 8020584083871	Axle Front	Thickness 19 mm
Width 129 mm	Height 71 mm	Braking system TRW
Wear indicator Prepared for wear indicator	WVA number 25326	Accessories With brake caliper bolts

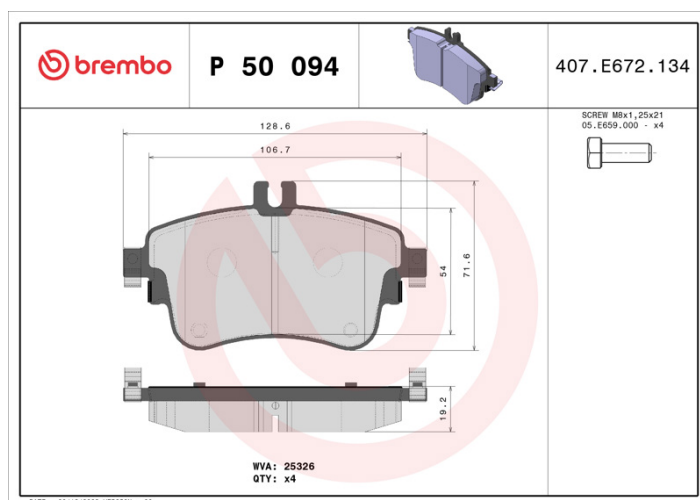

COMPATIBLE VEHICLES

COMPATIBLE OE PART NUMBERS

0004201405 MERCEDES-BENZ

0004202902 MERCEDES-BENZ

0064204820 MERCEDES-BENZ

0084200420 MERCEDES-BENZ

A0004201405 MERCEDES-BENZ

A0004202902 MERCEDES-BENZ

A0064204820 MERCEDES-BENZ

A0084200420 MERCEDES-BENZ
