



# BRAKE PAD

## P 50 132

The P 50 132 brake pad is synonymous with reliability

The Brembo brake pad guarantees ultimate safety when braking thanks to the use of more than 100 different compounds, designed according to the type of vehicle and use. Stopping distances reduced to a minimum, maximum driving comfort and silent operation are the most important features of Brembo materials. Brembo brake pads are supplied together with an extensive range of accessories and assembly kits for professional-standard installation.



- ✓ OE-equivalent
- ✓ Brembo quality
- ✓ ECE-R90 certificate
- ✓ Safety
- ✓ Performance
- ✓ Comfort
- ✓ With accessories

### Technical specifications

EAN code <b>8020584084298</b>	Axle <b>Rear</b>	Thickness <b>18 mm</b>
Width <b>146 mm</b>	Height <b>59 mm</b>	Braking system <b>TRW</b>
Wear indicator <b>Prepared for wear indicator</b>	WVA number <b>25163,25164</b>	Accessories <b>With accessories With brake caliper bolts</b>

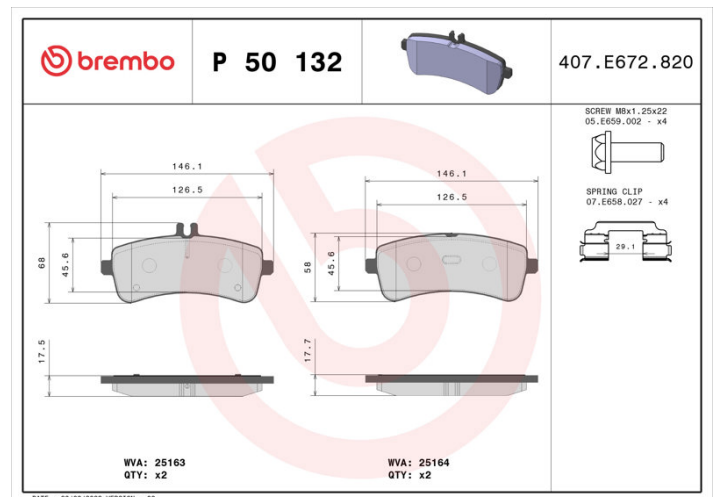

**COMPATIBLE VEHICLES**

## COMPATIBLE OE PART NUMBERS

0004203700	MERCEDES-BENZ
------------	---------------

0004204004	MERCEDES-BENZ
------------	---------------

0004204504	MERCEDES-BENZ
------------	---------------

0004208305	MERCEDES-BENZ
------------	---------------

0004209202	MERCEDES-BENZ
------------	---------------

A0004203700	MERCEDES-BENZ
-------------	---------------

A0004204004	MERCEDES-BENZ
-------------	---------------

A0004204504	MERCEDES-BENZ
-------------	---------------

A0004208305	MERCEDES-BENZ
-------------	---------------

A0004209202	MERCEDES-BENZ
-------------	---------------